



Помпа потопяема дренажна за фекални и отпадни води City Pumps TITAN 10/35M

RANGE OF PERFORMANCE

Flow rate up to 500 l/min (30 m³/h)
Head up to 15 m

LIMITS OF USE

Depth up to 10 m
Liquid temperature up to + 40°C
Passage of solid bodies max Ø 35 mm for TITAN/35
Passage of solid bodies max Ø 45 mm for TITAN/45
For continuous duty: minimum immersion 290 mm from pump base

INSTALLATION AND USE

THE PUMPS IN THE TITAN SERIES ARE MADE OF EXCEPTIONALLY ROBUST HEAVY-GAUGE CAST IRON, RESISTANT TO ABRASION AND ARE EQUIPPED WITH A VORTEX TYPE IMPELLER. THEY ARE RECOMMENDED FOR DRAINING WASTE WATER CONTAINING SUSPENDED SOLID BODIES, SEWAGE AND WATER MIXED WITH MUD.

GUARANTEE 2 YEARS subject to our general terms of sale.

CONSTRUCTION CHARACTERISTICS

- **PUMP BODY:** cast iron, with threaded port ISO 228/1.

- **MOTOR CASING AND BASE:** cast iron.
- **IMPELLER:** vortex in stainless steel AISI 304.
- **MOTOR SHAFT:** stainless steel EN 10088-3 - 1.4104.
- **DOUBLE SEAL:** mechanical seals silicon carbide - ceramic - NBR, with oil barrier chamber and inner lip seal to protect the seal in the event of dry running.
- **MOTOR:** submersible asynchronous for continuous duty.
TITAN M: single-phase 220÷240 V - 50 Hz with thermal overload protector.
TITAN: three-phase 380÷415 V - 50 Hz.
- **INSULATION:** class F.
- **PROTECTION:** IP 68.

STANDARD FEATURES:

- TITAN M (single-phase)**
 - Float switch.
 - Neoprene power cable "H07 RN-F" length **10 metres** with Schuko plug.
 - Control box with capacitor (Protection IP 64).
- TITAN (three-phase)**
 - Neoprene power cable "H07 RN-F" length **10 metres**.

OPTIONS ON REQUEST

- ⇒ control box for three-phase pumps 1.1 kW
- ⇒ single-phase pumps without float switch
- ⇒ other voltages or frequency 60 Hz



CONSTRUCTION AND SAFETY STANDARDS

EN 60034-1

IEC 34-1

CEI 2-3



DIMENSIONS

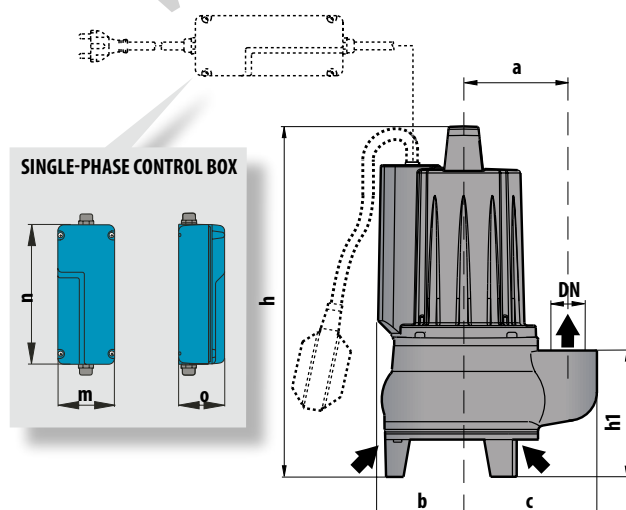

Typical installation

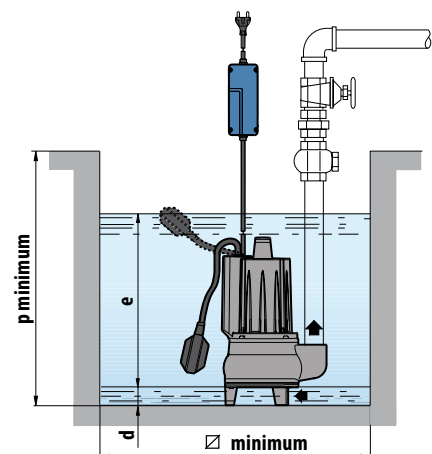



TITAN 35-45

VORTEX submersible pumps

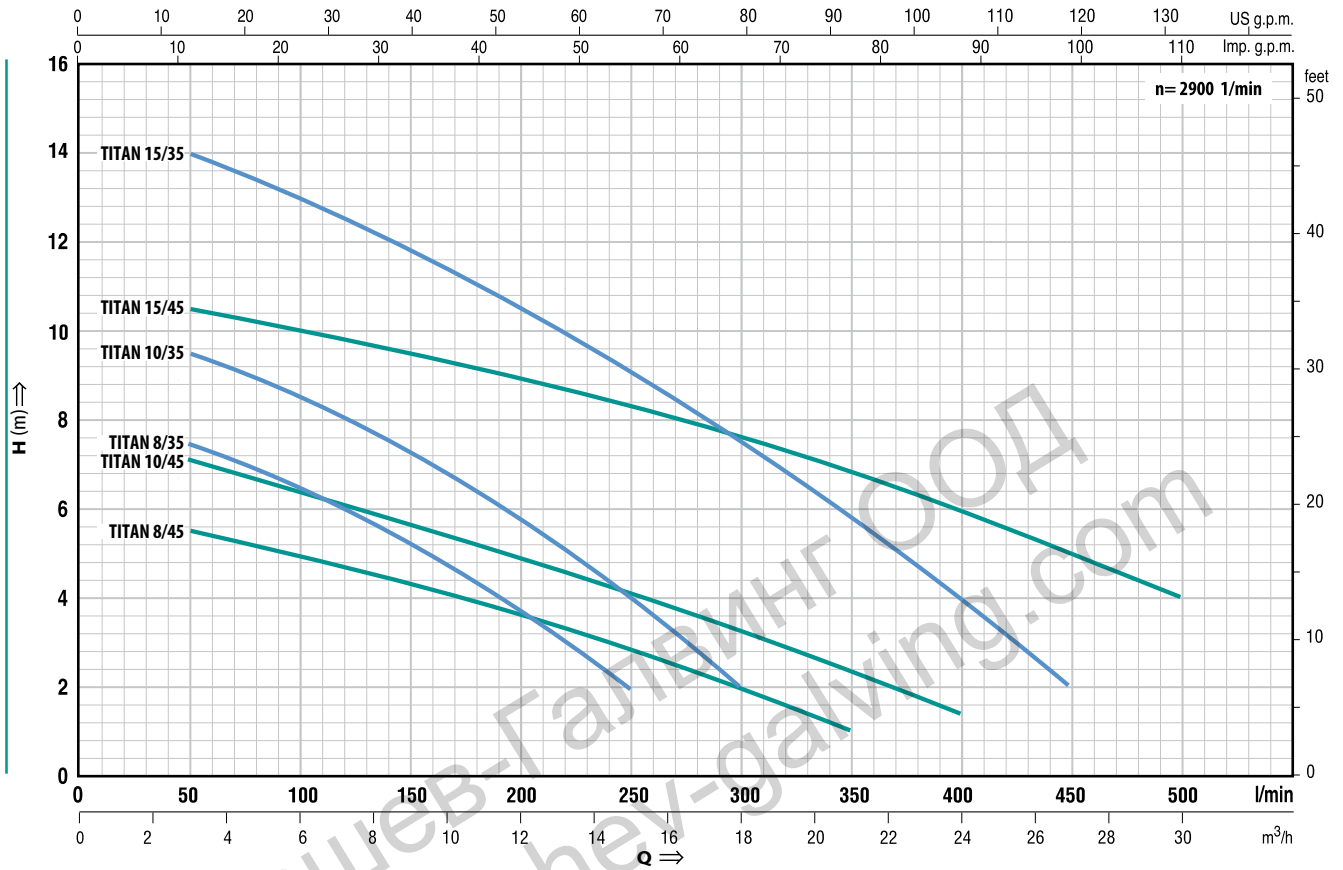

Tolerance of the performance curves according to EN ISO 9906 App. A.

TYPE		POWER		m³/h l/min	H metres												
Single-phase	Three-phase	kW	HP		0	3	6	9	12	15	18	21	24	27	30		
				0	50	100	150	200	250	300	350	400	450	500			
TITAN 8/35M	---	0.60	0.85	8.4	7.5	6.5	5.2	3.7	2								
TITAN 10/35M	TITAN 10/35	0.75	1	10	9.5	8.5	7.2	5.8	4	2							
TITAN 15/35M	TITAN 15/35	1.1	1.5	15	14	13	11.8	10.5	9	7.5	6	4	2				
TITAN 8/45M	---	0.60	0.85	6	5.5	5	4.4	3.6	2.8	2	1						
TITAN 10/45M	TITAN 10/45	0.75	1	7.5	7	6.5	5.8	5	4	3.2	2.4	1.5					
TITAN 15/45M	TITAN 15/45	1.1	1.5	11	10.5	10	9.5	9	8.3	7.5	6.8	6	5	4			

DIMENSIONS AND WEIGHTS

TYPE		PORT DN	passage of solid bodies	DIMENSIONS mm											kg		
Single-phase	Three-phase			a	b	c	h	h1	m	n	o	d	e	p	∅	1~	3~
TITAN 8/35M	---	1 1/2"	∅ 35 mm	105	90	137	350	123	81	200	66	40	adjust- able	500	500	17.0	-
TITAN 10/35M	TITAN 10/35				92	143	370	133				20.9				19.8	
TITAN 15/35M	TITAN 15/35			90	150	375	148	18.0				-					
TITAN 8/45M	---	2"	∅ 45 mm	110	90	150	375	148	81	200	66	55	adjust- able	500	500	19.7	18.0
TITAN 10/45M	TITAN 10/45				97	163	395	153				21.9				20.8	
TITAN 15/45M	TITAN 15/45			120	163	395	153	21.9				20.8					